

The GENERAL ENGINE PRODUCTS OPTIMIZER 6500 is used as the engine for the PENINSULAR 400 T series of marine engine. The PENINSULAR Diesels can be coupled with the Konrad, MerCruiser Bravo and Volvo stern drives. The Replacement parts can be readily obtained anywhere in the world through any General Motors, General Engine Product or PENINSULAR dealer or distributor at a far lower cost than competitors. The OPTIMIZER 6500 is the same engine as used in the HUMMER* Hum-V military vehicle the toughest vehicle in the world. Peninsular orders each engine with a low compression piston for marine use.

STANDARD SPECIFICATIONS

ENGINE TYPE:	Four Cycle	NUMBER OF CYLINDERS:	Eight
BORE AND STROKE:	4.06" x 3.82"	DISPLACEMENT:	400 cu.in.
FUEL PUMP:	Stanadyne-Mechanical	WEIGHT (DRY):	1020 lbs.

MODEL

SPECIFICATIONS

400T	HORSEPOWER: 220 BHP at 3600 RPM	PEAK TORQUE: 389 ft.lbs. at 2800 RPM
400TMR	HORSEPOWER: 270 BHP at 3600 RPM	PEAK TORQUE: 446 ft.lbs. at 2800 RPM
400TA	HORSEPOWER: 310 BHP at 3600 RPM	PEAK TORQUE: 469 ft. lbs at 2800 RPM
400TAI	HORSEPOWER: 340 BHP at 3600 RPM	PEAK TORQUE: 495 ft.lbs. at 2800 RPM
400TT	HORSEPOWER: 400 BHP at 3600 RPM	PEAK TORQUE: 600 ft.lbs. at 2200 RPM

STANDARD EQUIPMENT

Transmission Oil Cooler	Sea Water Pump 1.5" Inlet	Heat Exchanger	Aftercooler
Oil Pressure Sender	Tachometer Tab on Alternator	Cast and Turned Aluminum Pulleys	Top Mount Starter
Water Temperature Sender	Pan Mounted Engine Oil Cooler	Stainless Bolts and Fasteners	Alternator 12 Volts, 51 Amp
High Capacity Oil Pan	Fresh Water Cooled Manifolds	Fresh Water Cooled Turbocharger	Aluminum Flywheel Housing

OPTIONAL EQUIPMENT

MerCruiser Steering Cylinder	Polished Accessory Package	Instrument Panel - Includes: Tachometer, Hour Meter, Voltmeter, Temperature and Oil Pressure Gauge, Key Switch, Panel Lights, Water Temperature Alarm Lights and Buzzers
Alternator 90 Amp Upgrade	Power Steering Pump	
Oil Drain Kit	Wiring Harness Extensions 12 and 18'	
Cabin Heat Provision	Wiring Harness "Y"Connection	
Morse Cable Connection Kit		

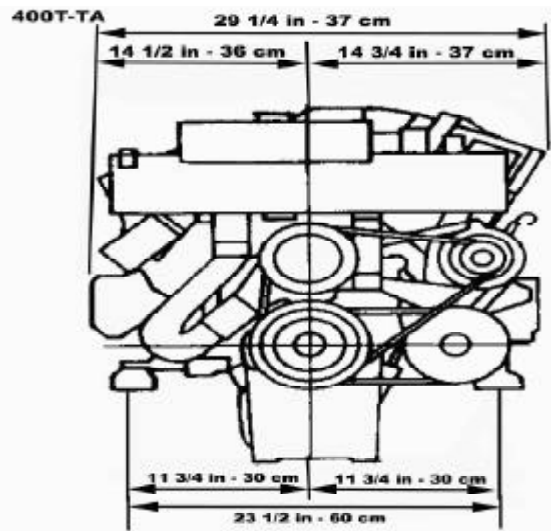
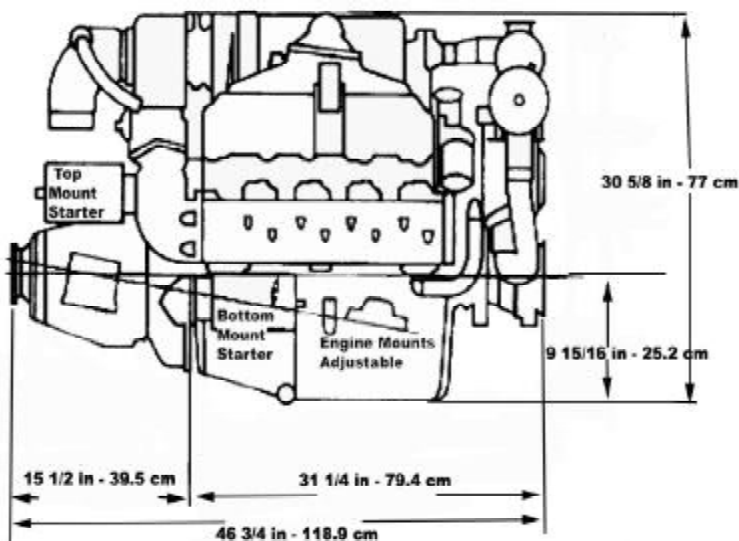

* Hummer is a registered trademark of the GM Corporation.